

# LOW CYCLE FATIGUE

Simplicity by Design, Results you can Trust





At Instron, we are committed to providing the most intuitive and user-friendly systems available for materials testing. We believe it is usability that allows all technicians to approach an Instron Test System with confidence and deliver the results they need first time, every time.

## UNDERSTANDING LOW CYCLE FATIGUE AND STANDARDISATION

### Strain-controlled Fatigue Testing

Low Cycle Fatigue (LCF) testing studies materials and components in which plastic strains are expected to be induced in the materials under real-world loading conditions. When researching the effects of plastic strain, the specific strain rate becomes a primary consideration, and data analysis is generally considered easier where the strain range (or amplitude) and mean level are kept constant throughout the test. It is, therefore, most common to run LCF tests in strain control and to maintain a constant strain rate by using a triangle waveform as opposed to the traditional sine wave profile used in load controlled high cycle fatigue.

Typical low cycle fatigue experiments have a total strain range which is <2% engineering strain. That means that good quality, reliable extensometers must be used (ISO 12106 specifies Class 1 according to ISO 9513, although typical modern systems provide class 0.5 at ambient), especially with the necessity for a relatively small parallel length and desire to work with smaller specimens. Mounting and positioning of the strain measurement device are critical in obtaining repeatable results while optimization and tuning of the control system is essential in meeting demanding test requirements.

### Gripping and Alignment

In an LCF test, the first few loading cycles are crucial in gathering accurate and useful data about the material under test. One of the critical considerations in guaranteeing the first cycle strain performance is to remove misalignment from the load string. Unlike traditional fatigue which often only applies tensile loading, LCF usually applies equal strain to the specimen in both tension and compression. This compressive loading amplifies the effects of misalignment and can potentially cause buckling or bending of the specimen as it is loaded. Although the effect is only subtle, this can lead to the incorrect measurement of the achieved strain levels and this, in turn, can produce inaccurately measured fatigue life and is particularly problematic during the initial loading cycles.

Test standards mandate specific limits which determine the maximum allowable misalignment. The quality of alignment is measured using a strain gauged specimen to measure the deflection caused by gripping misalignment, and this measurement process is well established in international standards. In the case of strain-controlled fatigue, the maximum allowable misalignment is 5% bending strain at any location, as measured according to ASTM E1012 or ISO 23788.

In addition to having a very well aligned load string, it is critical to have a gripping solution and a system design which has high lateral stiffness and can maintain the precise alignment during compressive parts of the test. Achieving and maintaining precise alignment between operators and tests is a challenge which requires superb product design, discipline in training and adherence to laboratory process.

### Temperature

Most materials which are exposed to plastic strain during their service conditions are also exposed to elevation or cycling of their operating temperature. While Instron does produce a range of systems for cycling temperature simultaneously with mechanical loading, LCF is exclusively carried out at elevated but fixed temperatures. The fundamental requirement is to minimize fluctuation of the specimen temperature during the isothermal test. Temperature variation during the test is limited to  $\pm 3$  °C for ISO 12106, or  $\pm 2$  °C for ASTM E606. As well as maintaining a constant specimen temperature, there is also guidance provided for the allowable variation in temperature along the parallel length of the test specimen and this is referred to as the “temperature gradient”. For ISO 12106, this is a fixed value of  $\pm 3$  °C. ASTM E606 uses slightly more generous limits which scale with temperature: the greater of  $\pm 2$  °C or  $\pm 1$  % of test temperature in °C.

The above looks at managing the steady-state conditions during the test, but there is also a consideration given to initial overshoots as the system is first heating up. Excessive overshoots can cause a change in the heat treatment state, or even the microstructure, of the material under test. For this reason, in recent years, the prime data users now demand no overshoot of temperature higher than the variation allowed during the test. In traditional systems, achieving this performance is highly dependent on the skill and expertise of test technicians to tune and optimize temperature control.

# CHALLENGES OF LOW CYCLE FATIGUE TESTING

Understanding The Primary Challenges Of Complex Strain-Controlled Fatigue

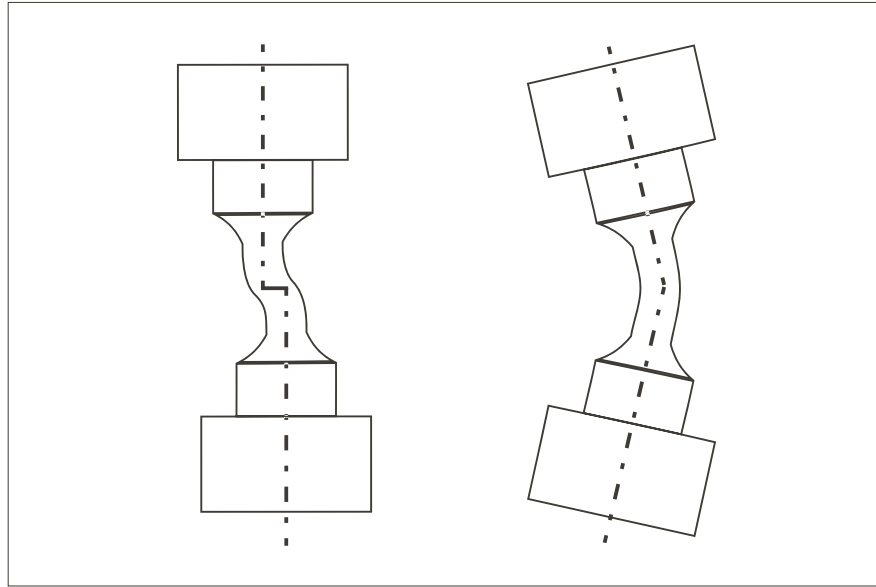

## Alignment

- Challenging demands of ASTM E1012 and its requirement for less than 5% bending on a specimen.
- Achieving proper alignment from test to test, independent of operator and specimen geometry.
- Repeatable alignment in tension and the lateral stiffness required to maintain proper alignment during compression.
- Real alignment, time after time and not just to meet your auditor's requirements.

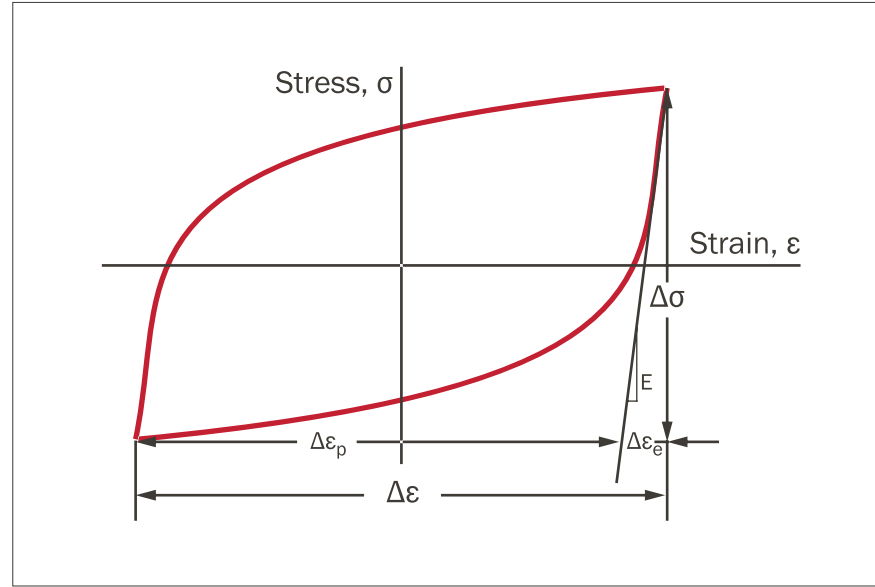

## Strain Control

- Challenging strain control targets which need to be met not just throughout the test but within the very first cycle.
- Maintaining control fidelity and targets through plastic deformation and both tensile and compressive loading.
- Achieving these test requirements without needing complex or advanced manual tuning and setup procedures which only expert users understand.

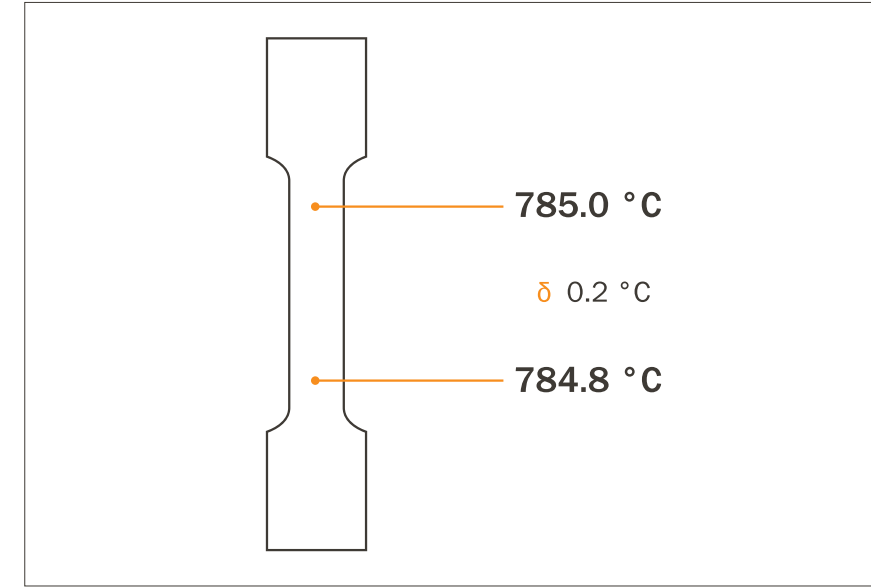

## Temperature Control

- Delivering precise high-temperature control up to 1000 °C without needing to understand the complexity and challenges of hardware based closed-loop control devices.
- Having the flexibility to achieve temperature control with and without specimen thermocouples to support testing of a wider variety of materials.
- The confidence to test without the need for a sacrificial specimen and to minimize the temperature overshoot during heat-up to preserve important material characteristics.



## Expertise

- The most common problem cited by labs that carry out Low Cycle Fatigue is the complexity of the test and the need for highly skilled experts to carry out even standardized low cycle fatigue tests.
- Our mission at Instron is to reduce the reliance on experts and to provide products and solutions that allow all technicians to have the confidence and ability to effectively carry out low cycle fatigue testing. Through our innovations, we will demonstrate that we have reduced complexity, increased repeatability and improved the quality of LCF results data.

# CLASS 5 ALIGNMENT TO ASTM E1012

Instron's High-Temperature Hydraulic LCF Loadstring

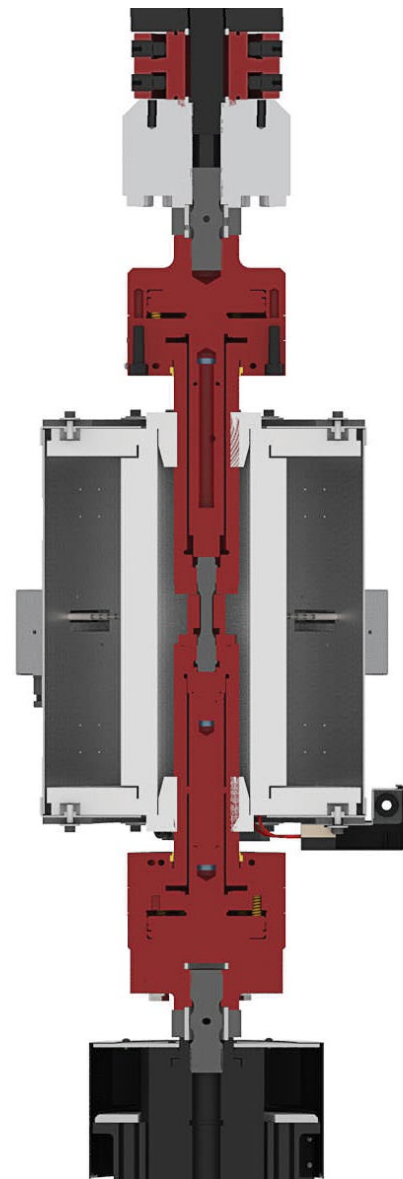

## Why is Alignment So Critical?

- Prevention of buckling under compression
- Reduction of side loads
- Repeatability of results between specimens and operators

## Requirements

- Due to the reverse-stress nature of LCF Testing, alignment is critical to ensure that strain measurement under compressive loading is not inaccurate as a result of misalignment.
- ASTM E1012 provides a procedure for measuring misalignment by recording the bending strain applied to a strain gauged specimen as a result of concentric and angular misalignment.
- The allowable bending strain is <5% which requires a highly repeatable process and high lateral stiffness of the system and load string to maintain alignment during compression.
- To achieve these challenging requirements, a holistic approach must be taken which considers both the load string, system and operating procedure.

## Challenges

- There is a significant difference between having an alignment expert align a system once and allowing a technician to achieve repeatable alignment, specimen after specimen.
- Most suppliers will only commit to an alignment specification under tensile loading conditions when the load string is said to 'self-align' due to the tensile force being applied.
- Due to the cost of high-temperature materials, the temptation is to provide a lightweight, low cost, compliant gripping solution which self-aligns in tension but cannot maintain its alignment in compression.
- The ideal alignment solution needs to work with both threaded and button-headed specimen geometries.



High-Temperature Hydraulic Grips with Class 5 Alignment to ASTM E1012



Instron AlignPRO Software guides You Through The Alignment Process

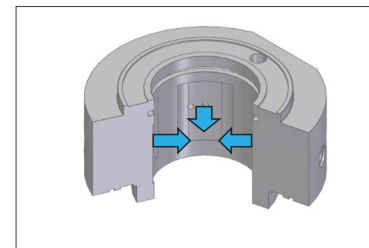

Hydrostatic Bearings to maintain Alignment during Compression as Standard

## Alignment You Can Rely On

- With our new hydraulic grip we have increased the grip diameter to 60mm to significantly increase lateral stiffness and maintain alignment under compressive loads.
- Combined with our guided AlignPRO software and hydro-static bearings we can achieve and maintain outstanding alignment even when changing specimens or operators.
- We have carried out over 600 alignment checks and shown repeatedly that we achieve Class 5 alignment to ASTM E1012 both in compression and in tension.
- Combine this with the one-touch pump for even more accessible alignment and further consistency between operators.

**600+**

Individual Checks with Strain Gaged Align Cell

**200+**

Compensated Alignment Checks

**100%**

within Class 5 Specification  
Most tests show 2% bending



## Button Headed Specimens

- This design offers optimum alignment as the machining tolerances that can be achieved are superior to that of a threaded specimen. This is the recommended design for new test specimens.
- A range of specimen inserts are available for use with the hydraulic pullrods which include a split design to surround the button head.
- Our alignment results for button headed specimens show this design repeatedly achieves < 1% bending in tension and <2% bending in compression.

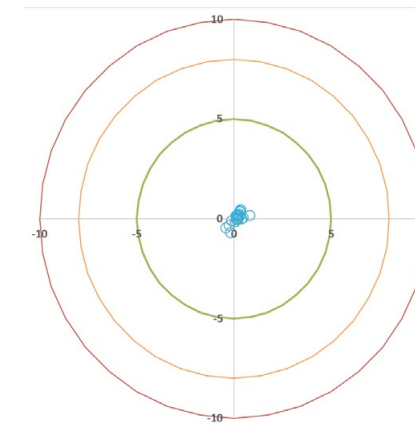

20 Consecutive Alignment Checks for a Button Headed Specimen at 1000 micro strain

## Threaded Specimens

- A threaded specimen is widely considered to be much more challenging to align as it relies on the inherent inaccuracies of a machined thread.
- However, if you have existing specimens or are unable to change your specimen design to a button head design, it is reassuring to know that you can use Instron's gripping solution for threaded specimens and achieve Class 5 alignment in both tension and compression.

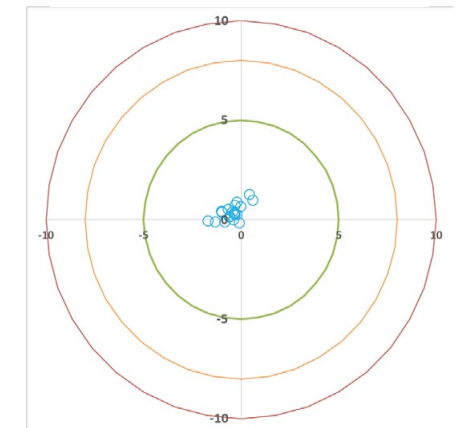

20 Consecutive Alignment Checks for Threaded M20 Specimen at 1000 micro strain

# ONE TOUCH INTEGRATED DIGITAL GRIP CONTROL

Simple And Repeatable Operation Removes Human Error

## Requirements

- Reverse-stress testing requires precise specimen clamping with zero backlash in the system.
- Historically this was achieved with a mechanical gripping solution using a torque wrench.
- To achieve repeatable Class 5 Alignment to ASTM E1012, hydraulic gripping is required.
- To minimize the variance introduced by the operator, the way in which torque or pressure is applied to the system must be highly repeatable.



Historically mechanical load strings used in high-temperature applications relied on the application of torque to the load string which introduces alignment offsets and inconsistency between operators. Mechanical load strings are therefore limited in practice to achieving only Class 10 alignment.

## Challenges

- Mechanical application of clamping force via a torque wrench introduces a torque to the specimen which will have a significant impact on alignment.
- Other suppliers rely on a hand pump to apply the clamping force to the specimen which is highly dependent on the operator to achieve consistent results.
- How quickly the pump is driven, ability to correctly read the dial gauge for pressure and coping with the inherent relaxation of pressure are all in the hands of the operator to ensure that the specimen is clamped correctly.



Other suppliers provide a manual hand pump to pressurize the grip which is an improvement over mechanical gripping but leaves an integral part of the gripping procedure open for inconsistencies between operators.

## One Touch Operator Independent Gripping



## Advantages

- Highly repeatable operator independent pressurization curves.
- Digitally adjustable clamping pressure with 1 Bar resolution.
- Remove human errors introduced by manual clamping and reading of dial gauge.
- Smooth application of clamping force and repeatable seating of specimen for world-class alignment.
- Convenient grip operation and grip status direct from frame control panel.
- Prevent accidental unclamping during test through a digital interlock feature.
- Compact micro-pump (150 x 265 x 340 mm) , 24V supply provided by main system controller.
- Only active during pressurization and silent during a test.
- 30-day pressure retention test with < 1 Bar lost pressure.
- Self-contained oil reservoir which contains “flame-out” self-extinguishing oil.



### Digitally Adjust Pressure

Adjust clamping pressure in 1 Bar intervals before activating grips and see a digital display of clamping pressure ergonomically located next to the grip controls.



### Integrated Grip Controls

When used with the electric micro-pump the grip controls are integrated into the 8800MT control panel. Close and open grips at the touch of a button and easily see the grip status with indicator lights.

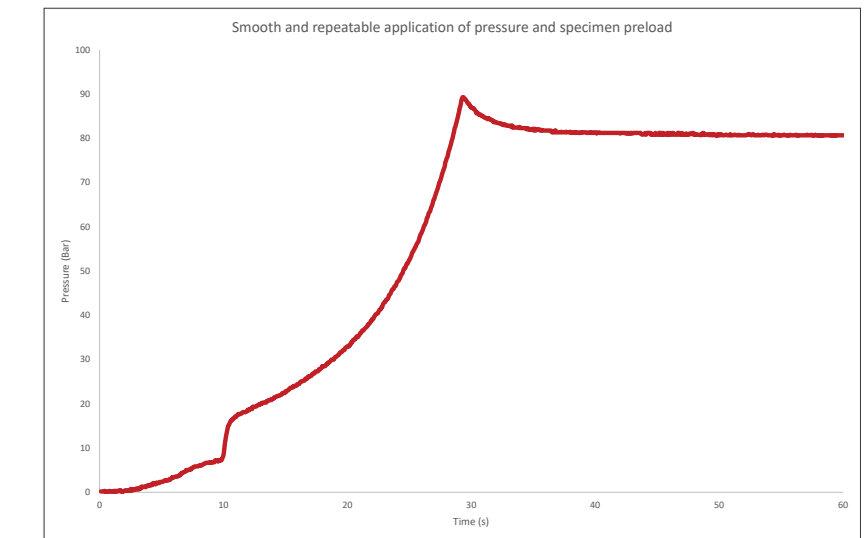

# TEMPERATURE CONTROL

Simple and Accurate Control of Temperature

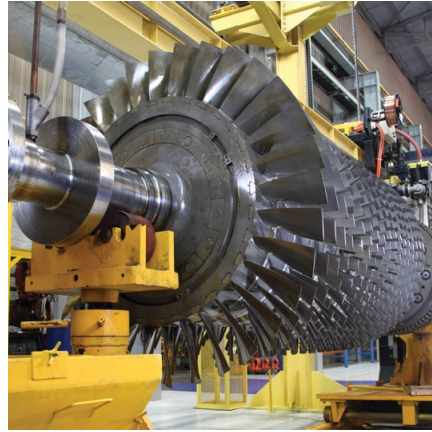

## Requirements

- Recreate service conditions of high-temperature metals up to 1000 °C
- Maintain accurate temperature control across specimen gauge length
- Avoid overshoots to study preserve critical material properties
- Control the specimen temperature directly when possible and the furnace temperature when thermocouples can't be attached to the specimen

## Challenges

- Traditional temperature tuning can take days to perfect with high levels of expertise required and long heating cooling times.
- Lack of flexibility offered by hardware-based temperature control limit.
- Sacrificial specimens are often required to develop and perfect temperature tuning parameters.
- Temperature performance is critical but dependent on the expertise of the individual.

## Intelligent Temperature Control Software

Control at high and low temperatures without manual tuning. Change performance from 'no-overshoot' to fast heat at the touch of a button. Intelligent control offers you the performance you expect across the whole range of temperatures your furnace can test to and not just in one small sweet spot.

## Advantages

- No tuning required, no physical temperature controllers to interact with and no complicated menus to learn about.
- Simple set point control with no overshoot.
- Flexible control modes to allow for testing with and without specimen thermocouples.
- Highly visual display with real-time charts and graphs.
- Comprehensive data logging, even before your testing starts, to maximize traceability of critical specimen data
- Unique calibrated thermocouple linearization facility that allows for compensated thermocouple data to be acquired.
- Seamless interfacing with other Instron software.
- Up to 8x thermo-couples with an easy to change panel to switch between thermocouple types



# STRAIN MEASUREMENT

Accurate and Repeatable Strain Measurement At Elevated Temperatures



## Requirements

- Class 0.5 Strain Measurement
- Temperatures up to 1000 °C
- Repeatable Positioning
- Repeatable Contact Force
- Hot-Unloading for Run-Out Tests
- No Extensometer 'walk' or slip during test or tuning

## Challenges

- Achieving results without sacrificing or pre-cycling specimens.
- Repeatable application of extensometer by all technicians to achieve consistent positioning, alignment/angle and contact force of extensometer.

## 1050°C Extensometer

- 2632 Series High-Temperature extensometers offer a range of gauge lengths and travel to suit your application
- Class 0.5 measuring device offering 1 micron accuracy
- Alumina rods suitable for use up to 1050 °C with a chisel-shaped profile at specimen contact points.
- Used in combination with high stiffness mount this device, typically used at <1 hz, has even been used for superimposed cyclic strain control at 30 Hz.

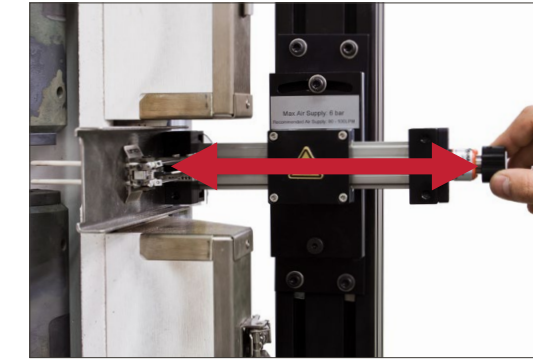
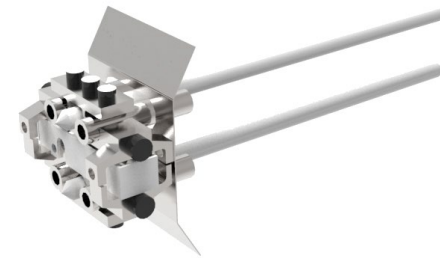

## Loading and Unloading

Easy and repeatable application of extensometer onto the specimen. Improve efficiency and accuracy for batches of specimens with similar geometry. Effortlessly remove the extensometer during a test, while hot for run-out testing.

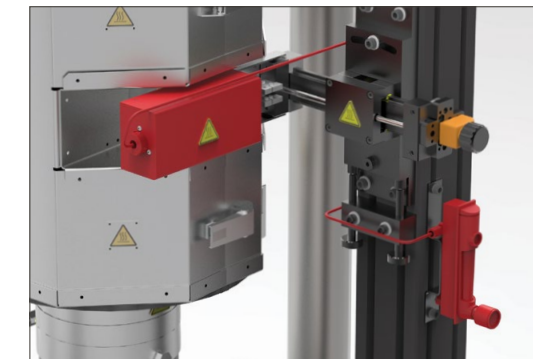

## Integrated Air Cooling

Maintain a constant temperature around the high-temperature extensometer for improved results. Air passes through a baffle into the extensometer housing to prevent turbulence, and flow of air is controlled with a control valve mounted on the high stiffness column.



## Repeatable Position

Numerical display with 0.1 turn resolution directly relating to the extensometer position. Easily use specimen contact point as a reference to achieve repeatable positioning.

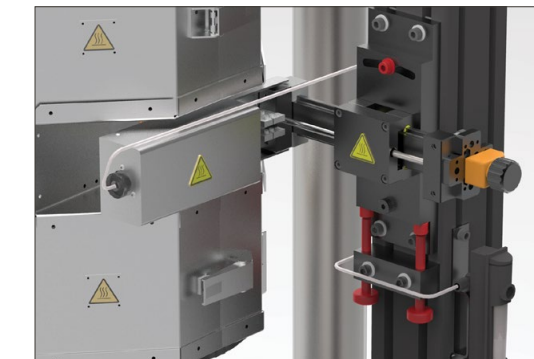

## Precision Adjustment of Height and Angle

The angle and the height of the extensometer can be optimized to suit a particular specimen geometry using these thumb wheels. Once set up, this arrangement can be used test after test to reproduce identical strain measurements.

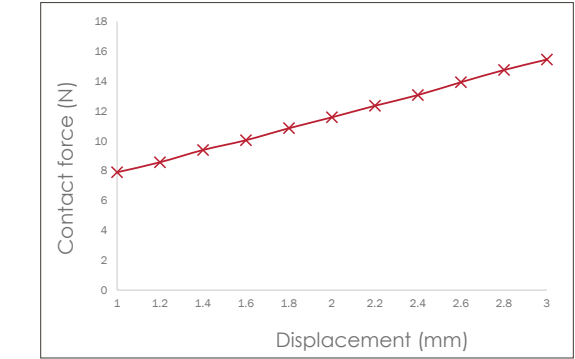

## Repeatable Contact Force

Each complete turn of the thumbwheel moves the extensometer 2 mm closer to the specimen and applies 4 N of extensometer contact force onto the specimen surface once in contact.

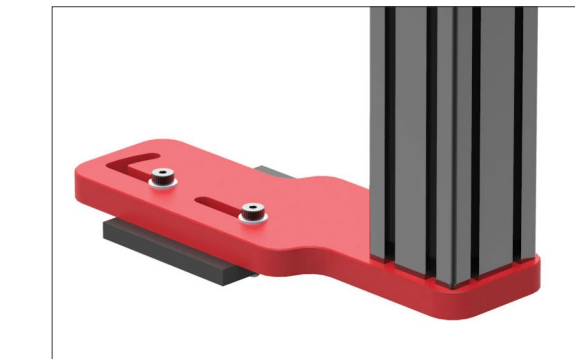

## Isolated from Furnace

Significantly improve the precision of extensometer mounting by moving away from crude furnace mounting and to an isolated, high stiffness mount which uses the frame for its reference location. Centered on your load string by design and no longer dependent on furnace location.

# STRAIN CONTROL

Machine Optimization And Control Which Every One Can Understand

## Typical Fatigue Requirements

- Force Control
- Ramp to force targets over as many as 100 cycles
- Tension-tension is most common
- Specimen operating in the elastic region
- No extensometer fitted

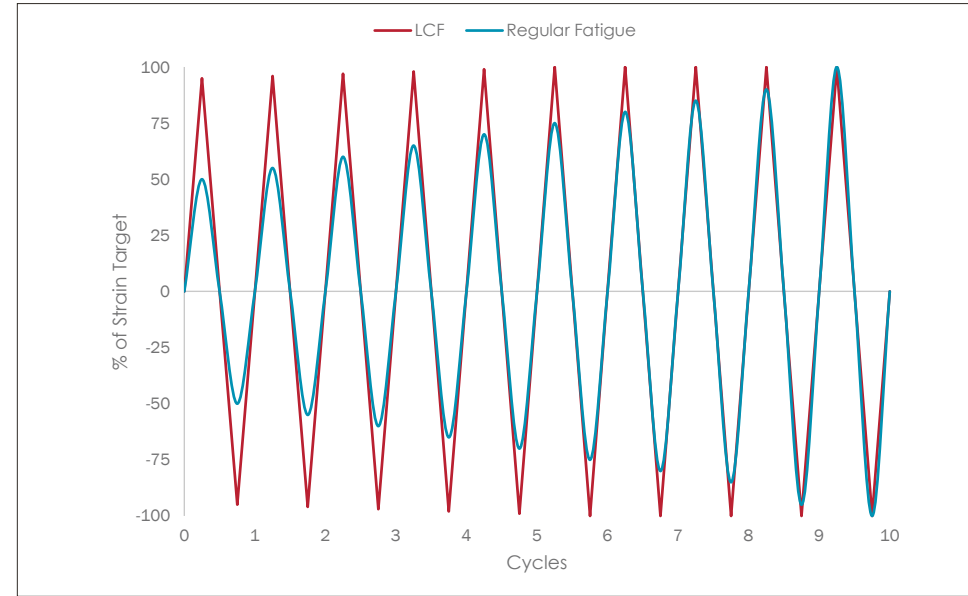

## Low Cycle Fatigue Requirements

- Strain Control
- **95% of Strain Target in first cycle**
- 99% of Strain Target within ten cycles
- 0% overshoot in any cycle
- Control through Plastic Deformation

## Challenges

- Systems require an experienced expert to manually optimize P.I.D. gains while cycling the specimen in strain control.
- No automation of tuning as traditional methods cause specimen damage, sudden movement, and extensometer slippage.
- A sacrificial specimen is needed as a result of pre-cycles applied during tuning.
- Extremely demanding strain tolerances expected in the very first cycle of the test (95% of target on the first cycle and 99% within ten cycles) all while the specimen is being plastically deformed.
- This is one of the most challenging aspects of Low Cycle Fatigue, and it should not be underestimated.

## Patented Stiffness Based Tuning

Patented technology now available on Instron hydraulic systems that makes tuning repeatable and effortless even for strain controlled fatigue. Choose any control mode and tune all transducer channels with a single static ramp within the elastic region.

No pre-cycling, no manual tuning steps: simply choose your control mode and set the ramp target. The patented algorithm will tune strain, force and position control in seconds without damaging your specimen.

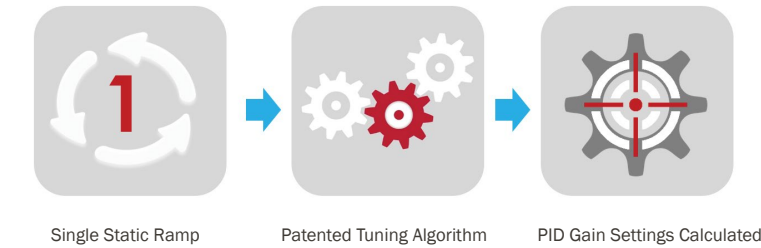

## Adaptive Control

To maintain fidelity through any changes to the specimen which occur as the plastic deformation occurs or as a result of serrated yielding, we can apply our adaptive algorithm which modifies the base tuning parameters in real time as the specimen properties change throughout the test. While this is not generally required for testing within the elastic region, it is ideal for strain-controlled fatigue tests to ASTM E606.

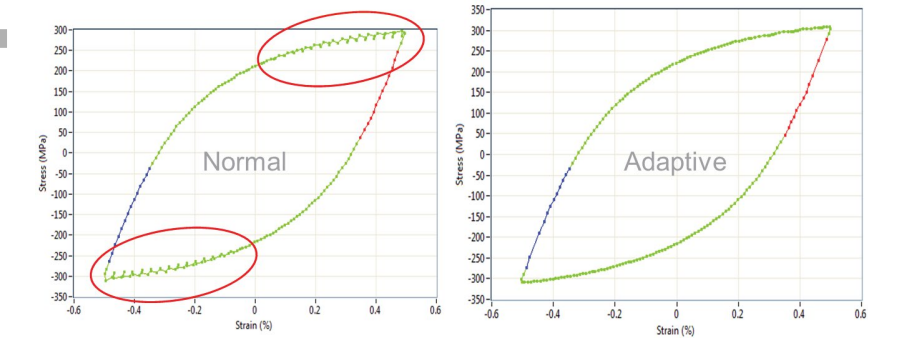

## Proven Results

Through the simple combination of stiffness based tuning and adaptive control, the system is capable of exceeding the tight tolerances required by ASTM E606 and even meeting the more demanding needs of industry leaders. These results show that the system achieved the 99% strain tolerance in the third loading cycle.

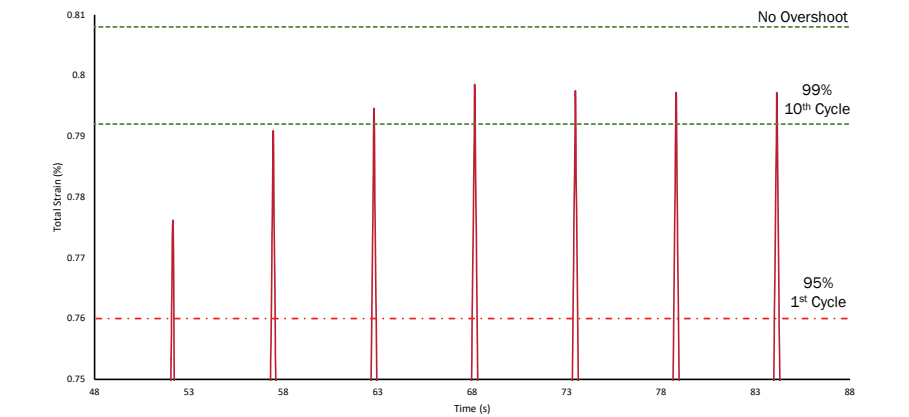

Evidence of Tuning Performance using Stiffness Based Tuning with Adaptive Control. The target strain was 0.8% with an R Ratio of -1.



# REDUCING RELIANCE ON EXPERTS

Simplicity By Design To Give You Results That You Can Trust

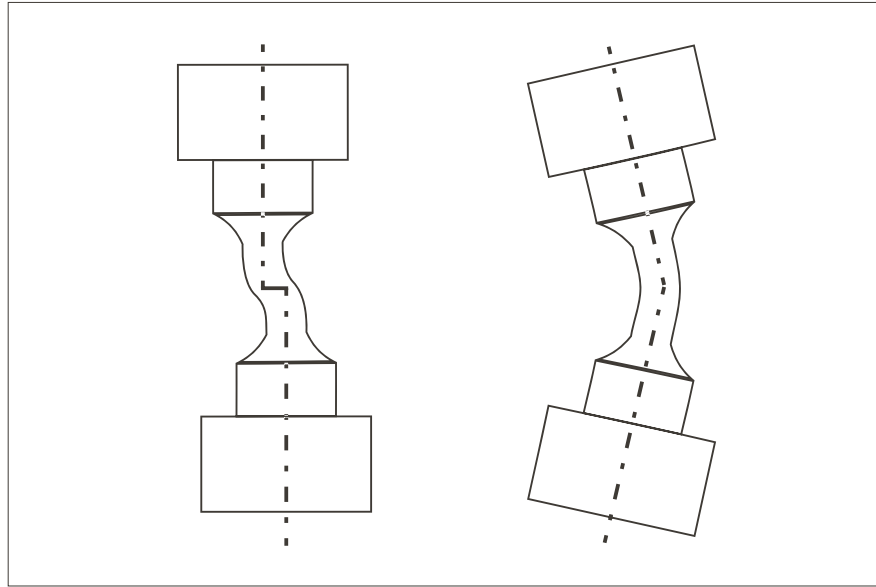

## Alignment

- ✓ Over 600 alignment checks on latest grip design to give you confidence in your alignment time after time.
- ✓ Detailed product design features to support the repeatable specimen loading procedure.
- ✓ A flexible design which guarantees Class 5 alignment for both threaded and button ended specimens.
- ✓ Large diameter grip design to improve lateral stiffness and maintain alignment during compressive loading.

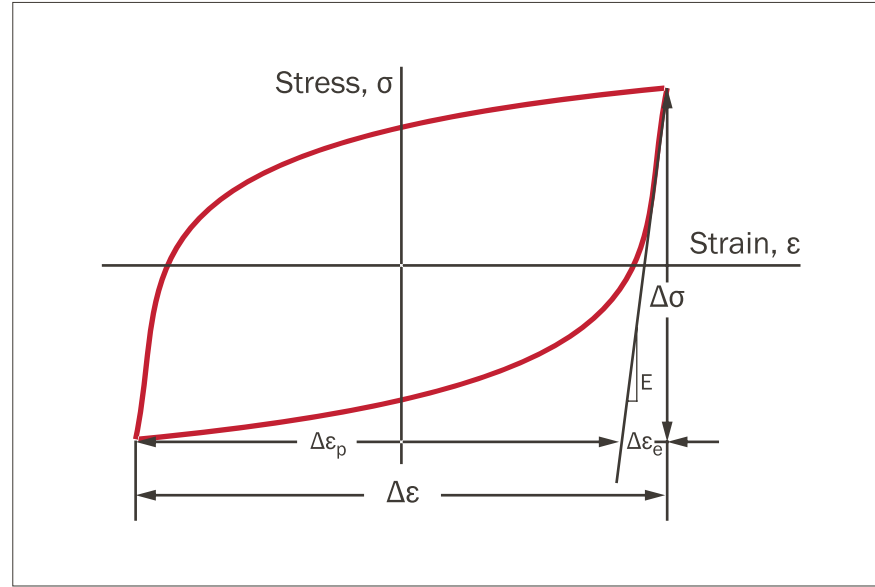

## Strain Measurement & Control

- ✓ Patented stiffness based tuning algorithm offers the only automated process for tuning with high-temperature extensometers.
- ✓ Simple control approach with only two simple steps: auto-tuning and adaptive control.
- ✓ Extensometer mounting independent of the furnace for precision alignment and positioning relative to the specimen, not the furnace.
- ✓ Repeatable contact force using a linear slide with a numerical display for repeatable application of extensometer and hot unloading.

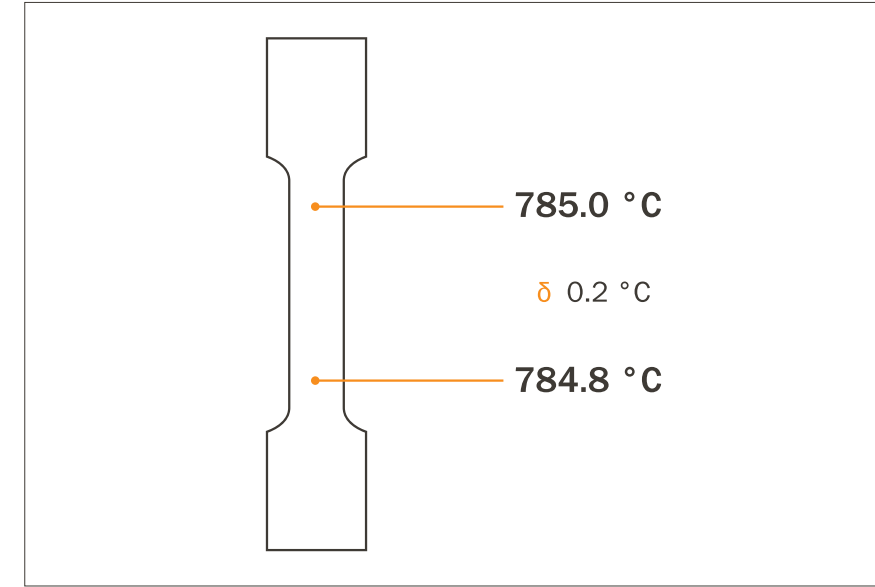

## Temperature Control

- ✓ Intelligent software furnace controller with no manual tuning required, just input set point and ramp rate.
- ✓ Complete data logging facility even before the test, all data parameters are logged for improved traceability.
- ✓ A flexible control architecture that supports testing both with and without specimen thermocouples at the click of a button.
- ✓ Calibrated thermocouple compensation curves that can be used to improve the accuracy of your temperature data.



## Expertise

- ✓ Easy to follow video guide and product features to ensure repeatable specimen insertion.
- ✓ One-touch gripping that achieves Class 5 alignment to ASTM E1012.
- ✓ Tuning that anyone can understand and apply to the system with confidence.
- ✓ Temperature control that just works. No need to understand complex control theory.

# COMPLETE SOLUTIONS

Instron Low Cycle Fatigue Systems



## 8801 Servohydraulic System

- 100 kN Hydraulic Frame with compact footprint
- Extensive **capability** can also be used for High Cycle Fatigue
- Hydrostatic bearings provide excellent alignment characteristics



## 8802 Servohydraulic System

- 250 kN Fatigue rated high **stiffness** frame
- Extensive **capability** can also be used for High Cycle Fatigue
- Hydrostatic bearings provide excellent alignment characteristics

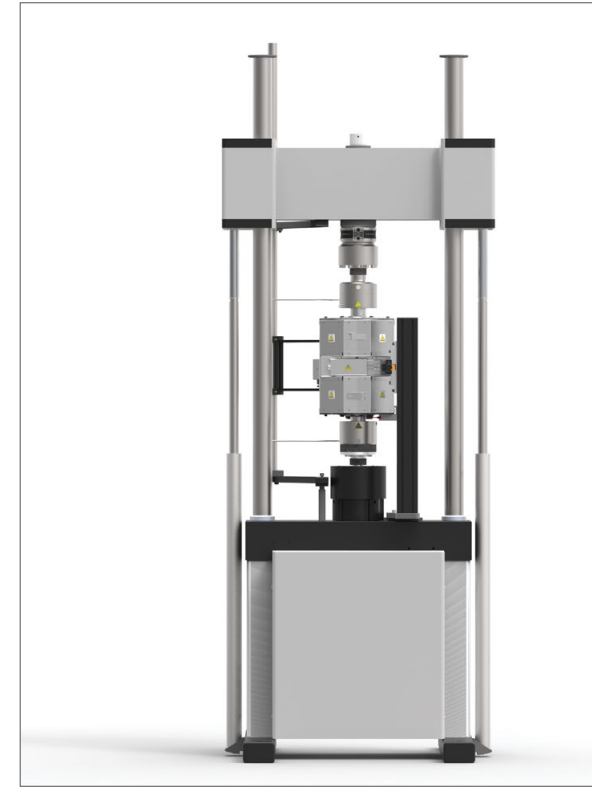

## 8862 Servohydraulic System

- Designed **specifically** for Low Cycle Fatigue testing
- Fatigue rated high **stiffness** frame
- Backlash-free electric actuator for through zero testing
- Speed range from 1  $\mu\text{m/hr}$  to 300 mm/min

SIMPLICITY BY DESIGN,  
RESULTS YOU CAN TRUST



[www.instron.com](http://www.instron.com)

Instron is a registered trademark of Illinois Tool Works Inc. (ITW). Other names, logos, icons and marks identifying Instron products and services referenced herein are trademarks of ITW and may not be used without the prior written permission of ITW. Other product and company names listed are trademarks or trade names of their respective companies. Copyright © 2018 Illinois Tool Works Inc. All rights reserved. All of the specifications shown in this document are subject to change without notice.

LCF\_BrochureV2